

w w w . s n o w t e k s y s t e m s . c o m

NITRO  **Xpress™**
USER & PARTS MANUAL
Version 1.2



© PREPARED BY
SNOW TEK
Systems Ltd

Index:

WARNINGS

SAFETY	2
TERMS	2
OVERVIEW	4

ORDER OF OPERATION

NITRO XPRESS SETUP INSPECTION	5
ATTACHING BARREL	6
ATTACHING THE MEASUMAX DIGITAL PROTRACTOR	7
ATTACHING NITROGEN REGULATOR AND FILLING HOSE	7
OPERATIONAL SAFETY CHECK	8
CHECKING THE UNIDIRECTIONAL SAFETY VALVE	10
CHARGING THE NITRO XPRESS FOR FIRING	11
LOADING AND ARMING THE ROUND	12
FIRING	13
FLIGHT CHECK OF THE ROUND	13
SHUTDOWN PROCEDURE	14
TROUBLE SHOOTING	16

Appendix:

A	NITROGEN REGULATOR OPERATOR INSTRUCTIONS	17
B	MEASUMAX DIGITAL PROTRACTER INSTRUCTIONS	19
C	RECOMMENDED FIRING CALLS FOR THE NITRO XPRESS	20
D	OPTIONAL ELECTRIC REMOTE FIRING SYSTEM	21
E	RECOMMENDED MAINTENANCE	22
F	PARTS MANUAL	23
G	PNEUMATIC CONTROL DIAGRAM	24

WARNINGS

1. Snowtek Systems Ltd recommends for shots greater than 300PSI that remote firing be used.
2. It is mandatory for shots greater than 400PSI that the electric firing option be used and high pressure regulator needs to be fitted PN AC 03. (Appendix D)
3. Never fire an Avalanche round without first checking the Avalanche round manufacturers' maximum pressure rating and never exceed this pressure.
4. The practice of extending the pneumatic firing lines to achieve remote firing is prohibited with the Nitro Xpress. This will cause uncommanded firing when the safety valve is opened. Remote firing must be either done with the lanyard system or using the optional electric firing control. (Appendix D)

Safety:

The Nitro Xpress is a nitrogen powered Avalauncher designed for the safe and efficient delivery of an Avalanche Explosive Round to the Intended target.

This manual addresses the safe and correct operation of the Nitro Xpress.

The Nitro Xpress has been designed with Operator and Public safety in mind.

The handling of explosives is to be carried out by a Blaster of Record only as per Governmental and or OHS Jurisdictional regulations.

It is a requirement to follow all good and safe practice when handling Explosives.

The firing of the delivery system requires 2 trained personel. One is called the Gunner and the other is called the Loader. A minimum of one operator must be a certified blaster for the OHS Juristiction.

It is essential that all staff and public are clear of the barrel when any pressure checks or firing is being carried out.

Compressed gas cylinders must be handled as per supplier's recommendations or by jurisdictional regulations.

Snowtek Systems Ltd recommends remote firing for shots with a greater charge pressure than 300 PSI.

Snowtek Systems Ltd states it is manditory to use the electric remote firing control for shots with a greater charge pressure than 400 PSI.

SnowTek Systems Ltd requires the operators of the Nitro Xpress Avalauncher to follow these operation procedures fully!

Terms:

Blaster of Record:

A person approved by the statutory authority to handle and use explosives.

Gunner:

The Gunner is required to be a Blaster of Record by certification as they are responsible for overseeing the co-ordination of the blasting operation while using the Nitro Xpress. They are responsible for all staff and public safety while operating the Nitro Xpress. The Gunner is also responsible for keeping a record of all firing.

Loader:

The Loader is required to be trained in the use of handling explosives as they are responsible for the safe handling and loading of the explosive avalanche round. The loader will also work with the Gunner to ensure the safe operation of the Nitro Xpress.

Main Valve:

This is the valve between the nitrogen pressure tanks and the barrel.

Pressure Release Valve:

This is the valve located on the control panel that is used to release the pressure from the Nitro Xpress pressure tanks.

Main Control Valve:

This is the valve located on the control panel that seats the main valve and allows nitrogen to flow into the Nitro Xpress pressure tanks.

Breech:

The mechanism that opens to allow loading of the Avalaunche round into the Nitro Xpress.

Breech Plug:

The plug which is removable to allow the avalanche round to be inserted into the barrel.

Firing Safety Valve:

The valve mounted on the gun as part of the interlock safety system.

Firing Valve:

A squeeze or pull valve that is actuated to release the main valve.

Interlock Safety System:

The locking system that prohibits the Nitro Xpress being fired when the breech is open or unlocked.

Shot Pressure:

The pressure required to deliver the avalanche round to its target.

Elevation Ram:

The mechanism for changing the elevation (angle) of the Nitro Xpress.

Directional Gearbox:

The mechanism for rotating the Nitro Xpress on its turn table.

Barrel Receiver:

The recess in the front of the Nitro Xpress that takes the machined end of the barrel.

Barrel Clamp:

The locking clamp that retains the barrel in the Nitro Xpress.

Safety Pressure Valve:

The over pressure release mechanism.

Holding Brake:

The friction device locking the turntable in place.

SPECIFICATIONS:

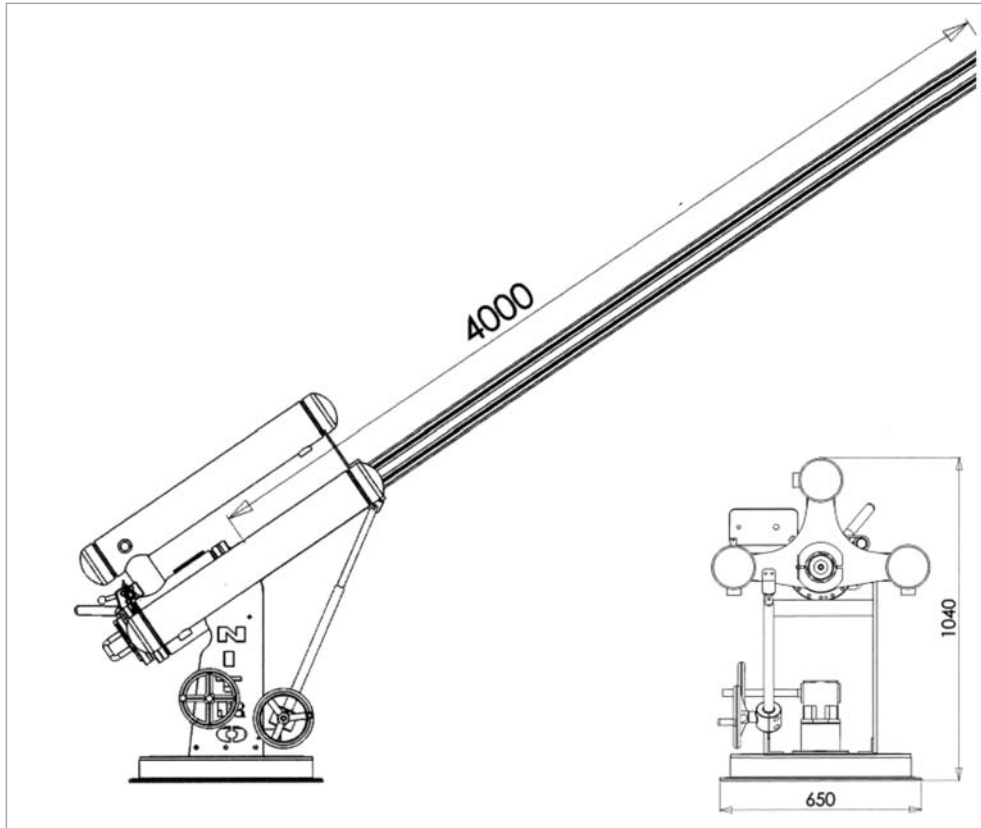

Nitro Xpress Height at 0°(minus barrel)	1040mm (40.9")
Nitro Xpress Height at 65°(minus barrel)	1375mm (54.1")
Barrel Length	4000mm (9.8')
Barrel Internal Diameter's	ID82.3mm (3.24")
Barrel Outside Diameter's	OD99.88mm (3.93")
Round Diameter's	80mm - 82mm (3.14" - 3.22")
Overall Length	4585mm (180.5")
Turntable Diameter	650mm (25.5")
Footprint (minus barrel)	1455mm x 710mm (57.2" x 27.9")
Propellant/Gas:	Dry Nitrogen
Design Pressure:	4136KPa (600psi)
Working Pressure	200 – 3450KPa(29 – 500psi)
Design Temperature	-25°C to 50°C (-13°F to 122°F)
Tank Capacity	45 litres
Weight (excluding barrel)	235kg (518lbs)
Barrel Weight	16kg (35lbs)
Pressure Vessel Standards	ASME 8, AS1210 Category 3 Canadian CNN.....

OVERVIEW:

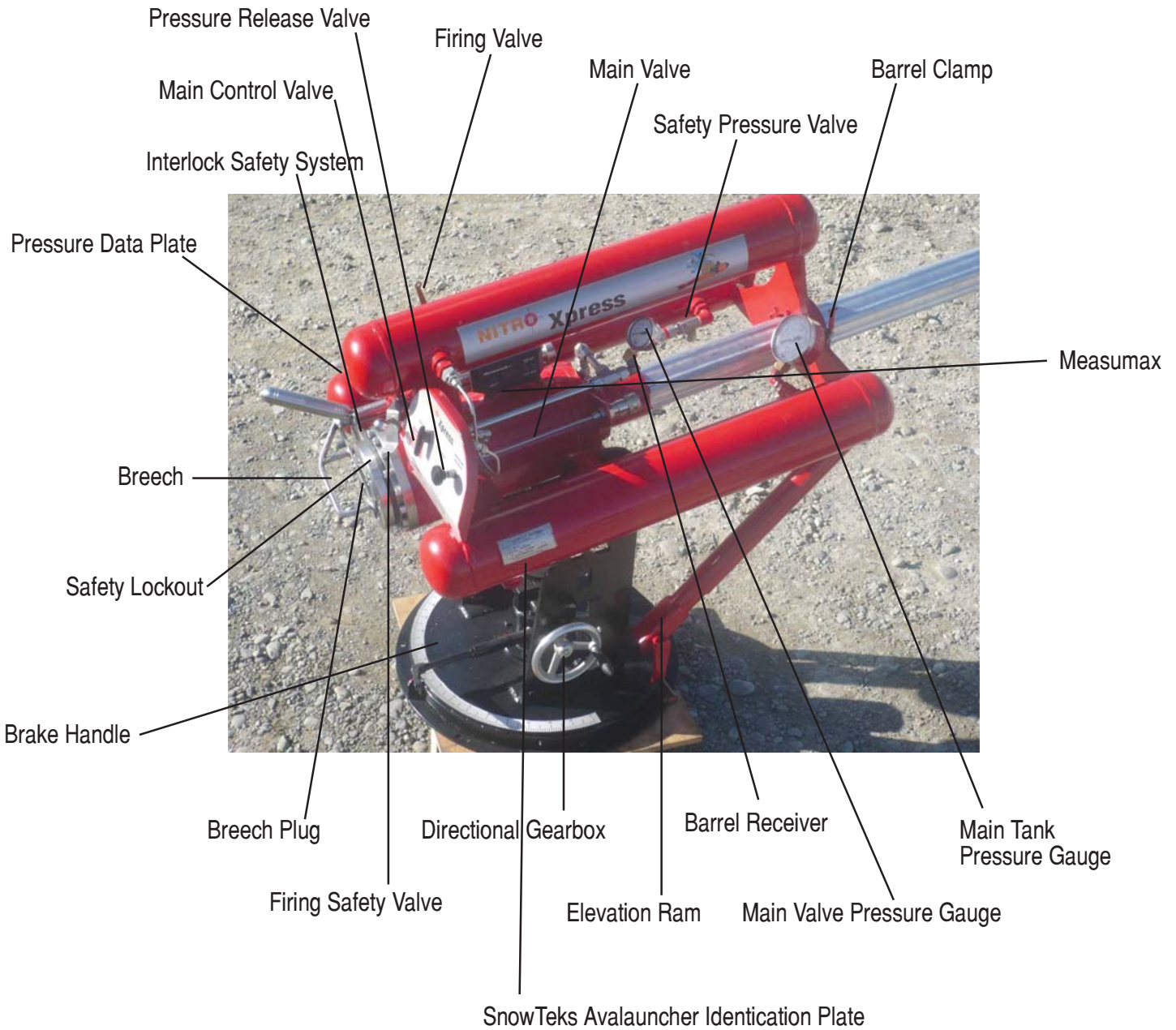

ORDER OF OPERATION:

SnowTek Systems Ltd requires the operators of the Nitro Xpress Avalauncher to follow the operation procedures fully!

1 NITRO XPRESS SETUP INSPECTION

1.0

Remove and store cover.



1.1

Remove lockout lock from the safety lever.
Open the pressure release valve on the main control panel to vent any residual pressure in the main tanks.



1.2

Release the brake lever.



1.3

Ensure the elevation ram and direction gearbox handles turn freely.



1.4

Remove barrel receiver cap and inspect receiver for foreign objects (e.g. ice or grit).
Wipe if necessary.



1.5

Ensure the barrel clamp is unlocked and free to move.



1.6

Open the breech and inspect the breech, breech plug and breech locking ring for foreign objects (e.g. ice or grit). If foreign objects are present carefully remove.



1.7

Inspect the safety pressure release valve for foreign objects (e.g. ice or grit) and remove if necessary.

1.8
Inspect the 2 pressure gauges for icing
and remove ice if present.



1.9
Inspect filling hose and filler socket for foreign
objects (e.g. ice or grit) and remove if necessary.



2 ATTACHING BARREL:

2.1
Remove the barrel from its storage tube.

2.2
Inspect the barrel for dents. If any are present refer to Trouble Shooting Guide.

2.3
Look through the barrel and ensure there are no foreign objects inside. Remove
any objects before continuing.

2.4
Slide the recessed end of the barrel into the end
of the Nitro Xpress through the barrel clamp and
into the barrel receiver. Take care to avoid denting
the end of the barrel.



2.5
Check the barrel is fully located into the barrel
receiver and the yellow indicator ring is not showing.



2.6
Close and lock the barrel clamp. Ensure the
barrel is secure and will not move under pressure.



3 ATTACHING THE MEASUMAX DIGITAL PROTRACTOR:

3.1
Clip the Measumax Digital Protractor into place.
Make sure it is firmly locked in place.



3.2
Turn the Measumax Digital Protractor on as per instructions (APPENDIX: B)

4 ATTACHING NITROGEN REGULATOR AND FILLING HOSE:

4.1
Secure the cylinder to an appropriate support that prevents the cylinder from falling as per supplier's instructions.

4.2
Open the cylinder valve slightly and close. This will clear the valve of any dust, water, or dirt which could be carried into the regulator and cause damage or an accident.

4.3
Fit the regulator onto the valve and tighten as per regulator manufacturer's recommendations (Appendix A).



4.4
Insert the filler hose end into the filler socket.

4.5
Push filler socket outer collar backwards to allow the filler hose end to snap home.



4.6
Release the filler socket outer ring to lock the filler hose end into place.

4.7
Give the filler hose end a gentle pull to ensure it is locked.



5.0
Electric Firing Control Option (for shots above 400 PSI).
Refer to Appendix D

6.0 OPERATIONAL SAFETY CHECK:

This operation is carried out by filling the Nitro Xpress to 50psi and firing. This operation is to be carried out twice. This is to check the operation of all components of the Nitro Xpress and ensure it is in safe working order.

Seal and operation check

6.1

Close the pressure release valve on the main control panel if open.



6.2

Ensure the breech plug is inserted and the breech locking ring is fully rotated to the left to lock the breech plug into place.



6.3

Aim the Nitro Xpress in a safe direction and raise the barrel using the elevation handle.

6.4

Open the nitrogen cylinder valve SLOWLY to allow pressure to gradually build up in the regulator thus preventing damage and or injury.
(Never lean over the regulator while opening the cylinder valve).

6.5

Check the connections between the cylinder and regulator for leaks. A leak is evidenced by a hissing sound. If a leak occurs close the cylinder valve and consult the nitrogen regulators operator instructions Appendix A.



6.6

Set the nitrogen regulator to 100psi.

6.7

Turn the main control valve to the "SEAT" position.



6.8

Allow the pressure to build on the valve pressure gauge to 70psi.



6.9

Turn the main control valve to the "OFF" position.



6.10

Watch the valve pressure gauge for 20 seconds to see if it maintains 70psi. A slow decrease is acceptable. If it falls at a fast rate reseal the main valve (see 6.7). If it continues to fall at a fast rate consult the Trouble Shooting Guide.



6.11

Adjust the pressure on the valve pressure gauge to 70psi by repeating steps 6.7 to 6.10.



6.12

Turn the main control valve to the "CHARGE" position to allow the pressure to build in the main tanks. Watch the tank pressure gauge and turn the main control valve to the "OFF" position when it reaches 50psi.

6.13

Listen for leaks from the pipe work and watch for major pressure drops on both gauges. If a major pressure drop occurs consult the Trouble Shooting Guide.

6.14

At this point the nitrogen will equalize in the main tanks and the pressure will drop approximately 10 - 20psi. If the pressure continues to drop consult the Trouble Shooting Guide.

6.15

Allow the pressure to equalize in the tanks and then adjust the pressure returning it to 50psi using the main control valve (see 6.12).

6.16

Ensure the Breech is closed and locked.

6.17

As the gun is about to discharge from the barrel ensure the firing area is clear of all public and staff. Personnel must be behind the Nitro Xpress.



6.18
OPEN the firing safety valve by rotating it to the left.



6.19
If manual firing, fire the Nitro Xpress by pulling the firing valve.
If electric firing, as per Appendix D



6.20
After firing, release the firing valve and move the firing safety valve right to the closed position.
If electric firing, as per Appendix D



6.21
Repeat steps 6.1 to 6.20 for second operation check.

7 CHECKING THE UNIDIRECTIONAL SAFETY VALVE:

Unidirectional Safety Valve Test

7.1
Turn the main control valve to "SEAT" position this will close the main piston and then allow the pressure on the main valve to build up to 20 PSI.



7.2
Turn the main control valve to the "CHARGE" position, as the main pressure tanks rise above 20 PSI check to see if the main valve pressure gauge rises with the main pressure gauge.



7.3
This checks the operation of the unidirectional safety valve, if the main valve pressure gauge doesn't rise once the tank pressure exceeds the main valve pressure the unidirectional safety valve has failed to function. Consult trouble shooting guide.



7.4
Open the Pressure release valve to vent the main tanks.

If the Nitro Xpress passes all these tests you can now proceed to fire avalanche rounds.

8 CHARGING THE NITRO XPRESS FOR FIRING:

Close the Breech

8.1
Ensure the Breech plug is in and the Breech is closed and locked.



8.2
Set the Nitro Xpress to the required direction and elevation.

Seat the Main Valve

8.3
Set the nitrogen regulator to 50psi above the required shot pressure.

8.4
Close the pressure release valve on the main control panel if open.

8.5
Turn the main control valve to the "SEAT" position,



8.6
Allow the pressure to build on the valve pressure gauge to a least 20psi above shot pressure.



8.7
Turn the main control valve to the "OFF" position.



Charge the Shot

8.8
Turn the main control valve to the "CHARGE" position to allow the pressure to build in the main tanks while observing the tank pressure gauge. When the Nitro Xpress reaches the required **shot pressure** turn the main control valve to the "OFF" position.



Is the Charge Holding?

8.9
At this point the nitrogen will equalize in the main tanks and the pressure will drop approximately 10 - 20psi. If the pressure continues to fall past 50psi below shot pressure and continues falling, release the main tank pressure by opening the Pressure Release Valve to release the pressure in the main tanks to leave the Nitro Xpress in a safe state. Now consult the Trouble Shooting Guide.

8.10

Allow the pressure to equalize in the tanks and then adjust the pressure as required to the shot pressure.

8.11

Inspect both gauges to ensure they are holding the correct pressure.

9 LOADING AND ARMING AN AVALANCHE ROUND:

9.0

Ensure the gun is holding the required pressure.



9.1

Check the Nitro Xpress is set to the required direction and elevation and make sure the brake is engaged.

Open Breech.

9.2

Move the breech locking ring handle to the RIGHT. Ensure the firing safety valve closes as it moves.



9.3

Remove the breech plug and swing it clear of the Breech.

Insert Avalanche Round.

9.4

Insert the round into the breech and arm as per the avalanche round manufacturers' instructions.



9.4A

Make sure that Wads/Arming discs are retained on the round as per round manufacturers' instructions. *2 examples are given.*



9.5

Check you have removed the transport safety pin to arm the avalanche round as per manufacturers' instructions.

Close and Lock Breech.

9.6

Swing the breech plug to line it up with the breech. Care should be taken **to retain any arming mechanisms on the avalanche round.**



9.7

Push the round into the breech with the breech plug until the breech plug is fully engaged.

9.7A

Warning!!

Never pull an Avalanche Round out of the breech once it has been loaded into the Nitro Xpress. This has the potential to arm the round producing a very hazardous condition. Once a round is inserted into the breech it must be fired.

9.8

Move the breech locking ring handle to the LEFT to lock the breech.

9.9

Pull on the breech plug handle to ensure it is engaged and locked.

10 FIRING:

10.1

Before firing re-check the Nitro Xpress is set to the required direction and elevation and make sure the brake is engaged.

10.2

Check the target area is clear and safe for firing. All staff and public must be aware of the firing and in a safe location.

10.3

Move the firing safety valve to the LEFT to open.

10.3A

For shots above 300psi Snowtek recommends remote firing

Firing

10.4

For electric firing consult Appendix D.
For manual firing pull and hold the firing valve until the Nitro Xpress has completely discharged. (via lanyard).
(this will open the main valve and release the nitrogen behind the round propelling it out of the barrel).
The Nitro Xpress will fire.

10.5

After firing release the firing valve and move the firing safety valve right to the closed position.
If electric firing, refer to Appendix D.



11 FLIGHT CHECK OF ROUND:

11.1

It is important to check the flight, impact and detonation of the avalanche round.

11.2

Record the direction, elevation, pressure and type of avalanche round fired.
(This information is useful to repeat the shot at a later date)

12 SHUTDOWN PROCEDURE:

After all firing has been completed.

Seat the Valve.

12.1

Set the nitrogen regulator to 50psi.

12.2

Turn the main control valve to the "SEAT" position.

12.3

Allow the pressure to build on the valve pressure gauge to 20psi to seat the main valve.

Then turn it to the "OFF" position.

12.4

Turn the main control valve to the "CHARGE" position to allow the pressure to build to 20psi in the main tanks.

Then turn to the "OFF" position.

(This maintains a positive pressure in the Nitro Xpress to prevent the ingress of moisture).

12.5

Lock out firing safety valve.

12.5A

Release brake.

Remove the regulator and hose.

12.6

Turn the nitrogen cylinder valve to the "CLOSED" or "OFF" position.

12.7

Relieve the pressure in the regulator by turning the adjusting knob clockwise fully. This will release any residual gas in the regulator and between the regulator and cylinder.

12.8

Remove the filler hose from the filler socket by pushing the filler socket collar ring backwards. This will unlock the filler hose end and then it can be removed.

12.9

Loosen the regulator by turning counter-clockwise and continue turning until the regulator is disengaged from the cylinder valve.

12.10

Store the regulator and filling hose carefully with inlet and outlet connections covered to avoid contamination and damage.

12.11

Replace cylinder cap on cylinder if supplied (as per cylinder supplier's recommendations).

12.12

Store the nitrogen cylinder as per supplier's recommendations.



Remove the Barrel.

12.13

Unlock the barrel clamp, rotate the barrel to loosen the seal, and remove the barrel from the Nitro Xpress.

12.14

Place the barrel into its storage tube, care should be taken not to damage the barrel in this process.

12.15

Replace the barrel receiver cap onto the barrel receiver.



Remove the Digital Protractor.

12.16

Turn off the Measumax Digital Protractor with its "ON/OFF" button, unclip and store in a safe dry location.

The "Measumax" must be removed from the Nitro Xpress between firings.

12.17

Cover the Nitro Xpress.



TROUBLE SHOOTING

Problem	Possible Cause	What to Do
<p>Small dent on the receiver end of barrel</p> <p>Dent in barrel large enough to see from inside</p>	<p>Hitting barrel receiver when inserting barrel</p> <p>Mishandling</p>	<p>Dress outside and inside of barrel to remove minor Damage</p> <p>Replace Barrel Call your Nitro Xpress Service Center</p>
<p>Valve pressure gauge fails to rise</p>	<p>Nitrogen cylinder empty</p> <p>Nitrogen regulator is not set correctly</p> <p>Filling hose not connected correctly</p> <p>Leak in pipe work</p>	<p>Replace with full cylinder</p> <p>repeat steps 6.4 to 6.6</p> <p>repeat steps 4.4 to 4.7</p> <p>Call your Nitro Xpress Service Center</p>
<p>Sound of leak from pipe work</p>	<p>Fitting becoming loose with heating and cooling</p> <p>Crack in pipe work or gauge</p> <p>Main valve not seating</p>	<p>Release the pressure from the Nitro Xpress using release valve and tighten loose fitting with appropriate size spanner</p> <p>Call your Nitro Xpress Service Center</p> <p>Call your Nitro Xpress Service Center</p>
<p>Major pressure drop on main tank pressure gauge</p>	<p>Pressure release valve open</p>	<p>Close valve</p>
	<p>Leak in pipe work</p>	<p>Identify leak, use spanner to tighten leaking fitting or</p>
	<p>Main valve not seating</p>	<p>Call your Nitro Xpress Service Center</p>
<p>Main valve gauge fails to rise</p>	<p>Unidirectional safety valve iced up</p> <p>Unidirectional safety valve damaged</p>	<p>warm and de-ice</p> <p>Call your Nitro Xpress Service Center</p>
<p>Main tanks gauge still drops pressure</p>	<p>Pressure release valve open</p> <p>Leak in pipe work</p> <p>Safety pressure release valve tripped</p> <p>Main valve not seating</p>	<p>Close valve</p> <p>Use spanner to gently tighten fitting</p> <p>Call your Nitro Xpress Service Center</p> <p>Call your Nitro Xpress Service Center</p>

APPENDIX A:

Operating Instructions for BOC Nitrogen High Pressure Regulator used in the Refrigerant Flush System Model Number: NZRT50HP

Developed in conjunction with BOC Gases Australia Limited
Manufactured by Gasgep Pty Limited Melb

This Nitrogen Regulator has been designed for use in the BOC Refrigerant Flush System, with 0-3500 kPa (high pressure) regulated output for use with the new T50 Valve Cylinders.

Please follow the instructions provided for correct use.

SAFETY PRECAUTIONS

- Compressed gas cylinders must be handled with care and should be stored and secured in an upright position in a secure place where they will not be knocked over.
- Store and use cylinders in a well ventilated area and ensure they are not subjected to ambient temperatures above 55C or any source of radiant heat.
- Close the cylinder valve whenever the cylinder is being moved, not in use or empty.
- Cylinders should only be filled by the cylinder owner or with written permission of the cylinder owner in accordance with AS2030.1 and State Dangerous Goods Regulations.
- Read and understand the instructions and labels that accompany your compressed gas equipment and cylinder. Further information is available in the BOC Gases' Material Safety Data Sheet (MSDS) No. 030 available on request from the BOC Customer Service Centre.
- Additional information for compressed gases can be found in AS4332 "The Storage and Handling of Gas Cylinders".
- Check the cylinder label for fill pressure. Only Nitrogen gas cylinders with a fill pressure of 5Mpa at 15 degrees C (20Mpa max. inlet) should be connected to this regulator.
- Always remove the regulator before moving or transporting the cylinder (see "Closing the cylinder & removing the regulator" section of this leaflet).
- Never hold the regulator to lift the cylinder.

OPERATING INSTRUCTIONS

Attaching the regulator to the cylinder

1. Secure the cylinder to prevent the cylinder from falling.
2. Open the cylinder valve slightly and close. This will clear the valve of any dust, water or dirt that could be carried into the regulator and cause damage or accident.
3. Fit the regulator into the valve and hand tighten. Do not use a spanner or over tighten as this will damage the connector o-ring.
4. Open the cylinder valve S-L-O-W-L-Y to allow pressure to gradually build up in the regulator thus preventing damage and/or injury. Never lean over the regulator.
5. Check the connections for leaks. A leak is evidenced by a hissing sound. If a leak occurs refer to the "Faulty Operation and Maintenance" section of this leaflet.

Closing the cylinder & removing the regulator

1. After use turn the cylinder valve to the "close" or "off" position.
2. Relieve the pressure in the regulator by turning the adjusting knob clockwise fully in. This will release any residual gas in the regulator.
3. Loosen the regulator by turning counter clockwise and continue turning until the regulator is disengaged from the cylinder valve.
4. Store the regulator carefully with inlet and outlet connection covered to avoid contamination and prevent damage.
5. Replace the cylinder cap on cylinder if supplied with one.

FAULTY OPERATION AND MAINTENANCE

In the event of a leak from a cylinder or regulator, turn off the valve and do not attempt to use the cylinder.

No maintenance is to be performed on the regulator by the user.

Do not tamper with the regulator or cylinder under any circumstances.

For further information, please contact BOC on 1300 133 286 in Australia
or 0800 262 374 in New Zealand.

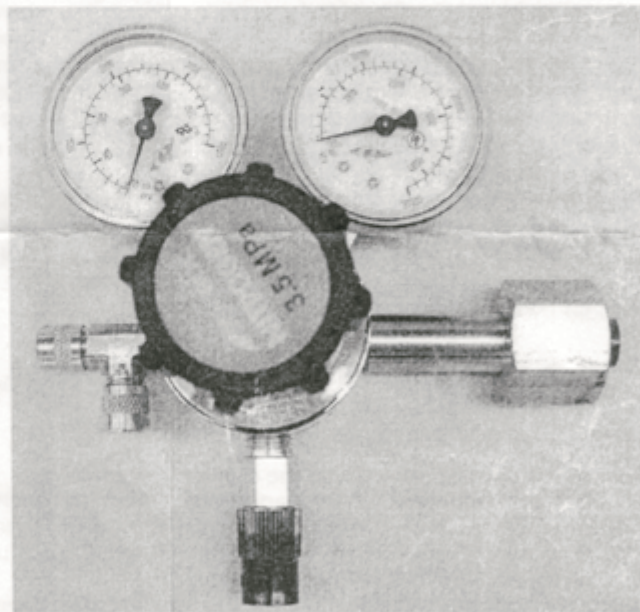

Made in Austr
BOC Limi
ACN 000 029 ;

APPENDIX B:

MeasumaX^{MDX}

Digital Protractor 35-204

Calibration

The Measumax DP-360 Digital protractor needs to be calibrated only before being used for the first time, or if the ON/OFF button is pressed for longer than 6 seconds.

<1>

Place the unit on a flat machined surface facing you with the lettering on the face right side up. Align with an edge or a line, then press ON/OFF button. The screen will display "-1-"

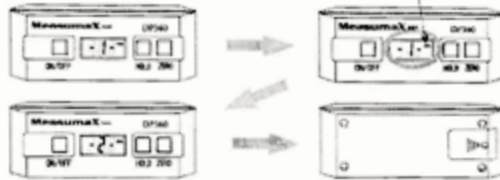

<3>

Wait six seconds until "-2-" is displayed

<2>

Press the ZERO button and the "-1-" will begin to flash

<4>

Rotate the unit in the horizontal plane 180 degrees, so that the lettering is facing away from you, but still the right side up. Align with the same edge or line. Press the ZERO button and "-2-" will flash. Wait six seconds until the actual angle is displayed.. The calibration is now finished

Functions

ON/OFF Button

For measurement mode simply press the button and the angle will be displayed. To refresh the reading press the button again. To switch off press the button and hold for 6 seconds. NOTE! If you press the button for longer than 6 seconds the "-1-" will be displayed and the unit will have to be recalibrated as above.

HOLD Button

To freeze the display for reading where the unit has to be moved before you can see the display first ensure that the unit has been sitting in the position for more than six seconds, then press the HOLD button once. The display will show the angle and display a flashing "HOLD". Wait until the "HOLD" symbol on the LCD stops flashing and remains static, or wait at least 6 seconds, then the unit can be moved to view the. To cancel the reading press the HOLD button once again.

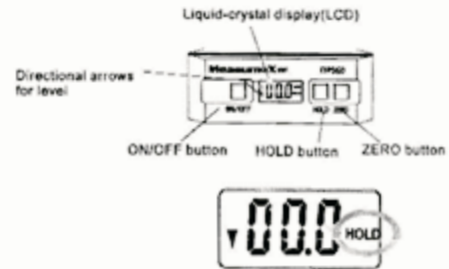

ZERO Button

HORIZONTAL MEASUREMENT
When the "ABS" icon is displayed the unit is in the horizontal measurement mode



HORIZONTAL MEASUREMENT

In the horizontal measurement mode the "ABS" icon will be displayed. Place the unit on the surface to be measured. Hold the unit in place for 6 seconds and the protractor will display the angle off the horizontal plane.

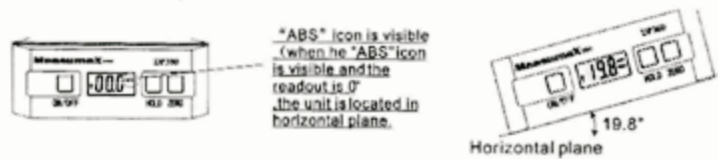

RELATIVE MEASUREMENT

Setting the alternate reference point. This function allows you to set any angle as the 0.00 reference point from which a measurement can be taken. E.G. You can set a surface that is 25 degrees off the horizontal plane as 0.00 so that you can use that surface to measure all other angles from

- In the horizontal mode the "ABS" icon will be displayed. Put the digital protractor on a surface 25 degrees off the horizontal plane
- Press the "ZERO" button to change to relative mode. (0.00 will be displayed)
- Place the protractor on a surface 60 degrees off the horizontal plane and 35 degrees will be displayed

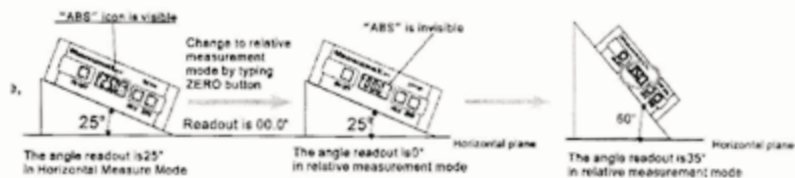

Technical Data. Full 360 degree range (90 x 4) - Resolution 0.1 degree. - Stainless Steel frame - Battery CR2032

Note ! The battery is not installed and is supplied only to test the system and may not have enough charge for normal use

www.measumax.com

APPENDIX C:

RECOMMENDED FIRING CALLS FOR THE NITRO XPRESS

SnowTek Systems Ltd recommends the following calls be adopted by the Gunner and Loader as part of the operation of the Nitro Xpress.

Gunner selects target and calls "Target (e.g. Rockbridge)."

Loader replies "Target (e.g. Rockbridge)."

Gunner sets direction and elevation and calls (e.g. Direction 25?, Elevation 55?).

Loader confirms settings and calls (e.g. Direction 25?, Elevation 55?).

Close the Breech.

Gunner calls "Seating Valve", then when the valve is seated calls "Valve Seated".

Loader replies "Valve Seated".

Gunner calls "Pressurizing to (e.g. 150PSI)".

Loader replies "(e.g. 150PSI)".

Gunner calls when the pressure is reached and holding Pressure Holding".

Gunner calls "Opening Breech".

Loader replies Opening Breech".

Gunner calls "Load Round".

Loader calls "Loading Round".

Loader calls "Round Loaded and Armed".

Gunner replies "Round Loaded and Armed".

Gunner calls "Locking Breech, Breech Locked".

Loader calls "Breech Locked".

Gunner Calls "Firing Safety Valve Open".

Loader replies "Firing Safety Valve Open".

Gunner calls "All Clear".

Loader replies "All Clear".

Gunner Calls "Ready to Fire, 5, 4, 3, 2, 1, Fire".

Gunner Calls "Firing Safety Valve Closed".

Loader call "Wadd Or Arming Disk Away".

Gunner calls "Round Armed".

Loader confirms impact and detonation.

Gunner to record shot setting and result.

APPENDIX D:

ELECTRIC FIRING CONTROL:

**Note: For shots above 300 PSI Snowtek recommends remote firing.
For shots greater than 400 PSI it is mandatory to use the electric remote firing control.**

1. Firing Valve.



2. Electric Connection.



3. Electric Firing Control.



4. Charger Unit.



Fitting Firing Control Valve.

(must be fitted with no pressure/rounds in the Nitro Xpress).

1. Pull back collar on firing line.



2. Fit Firing Valve.



3. Connect Electrical Connection.



4. Turn key on, push firing button.
(valve should be heard clicking).



5. Make sure key is turned off and removed.

To Electrically Fire.

1.1

Insert firing key

1.2

Turn key on, firing light will illuminate.

1.3

Push and hold firing button down until the Nitro Xpress has discharged.

1.4

Release the firing button.

1.5

Turn off the firing control and remove the firing key.

Recharge firing control every 100 shots or 3 months,
or if firing light fails to light.



When Firing Completed The Electric Valve Must Be Removed.

To Remove Electric Firing System.

2.0

Turn off Firing Control and remove key.

2.1

Disconnect Electric Connection.

2.2

Pull back collar on firing coupling and remove valve.



It is not recommended to leave electric firing valve on Nitro
between sessions freezing could cause problems.

2.3

Put firing valve back in tool box.

2.4

Charge firing control every 3 months or after 100 shots.



APPENDIX E:

RECOMMENDED MAINTENANCE

1. Charge Electric Remote Firing Control, if option taken.



2. Pre-season maintenance

2.1 Grease turntable at grease nipples on base.



3. Grease lifting cylinders.

Disconnect top clevis on cylinder while supporting tank assembly. Wind the elevation handle to extend cylinder until cylinder extends no further, pull on cylinder, the top section will come away. Grease thread with a waterproof grease and re-assemble.



4. Liberally spray WD40 over all moving parts.



AT THE END OF THE SEASON liberally spray all moving parts with DW40 lubricant spray.

PARTS LIST APPENDIX F



Part No. **TR 001**
Description **Valve Cylinder**



Part No. **TR 002**
Description **Valve Inner**



Part No. **TR 003**
Description **Nose Cone**



Part No. **TR 004**
Description **Piston**



Part No. **TR 005**
Description **Breech End Plate**



Part No. **TR 006**
Description **Locking Ring Retainer**



Part No. **TR 007**
Description **Breech Plug**



Part No. **TR 008**
Description **Breech Locking Ring**



Part No. **TR 009**
Description **Breech Locking Ring Handle**



Part No. **TR 010**
Description **Breech Slide**



Part No. **TR 011**
Description **Breech Slide Guide**



Part No. **TR 012**
Description **Seal Kit**



Part No. **TR 013**
Description **Barrel Locking Clamp**



Part No. **TR 014**
Description **Elevating Ram Top Retainer**

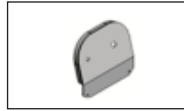

Part No. **TR 015**
Description **Control Panel**



Part No. **BR 001**
Description **Elevating Ram**



Part No. **BR 002**
Description **Side Plate**

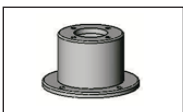

Part No. **BR 003**
Description **Gearbox Spacer**



Part No. **BR 004**
Description **Gearbox**



Part No. **BR 005**
Description **Coupling**

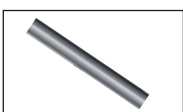

Part No. **BR 006**
Description **Side Plate Support**



Part No. **CR 001**
Description **Barrel**



Part No. **BR 007**
Description **Hand Wheel**



Part No. **BR 008**
Description **Trunnion Bearing**

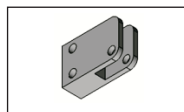

Part No. **BR 009**
Description **Elevating Ram Bottom Retainer**



Part No. **BR 010**
Description **Brake Shoe**



Part No. **BR 011**
Description **Brake Actuator**



Part No. **BR 012**
Description **Gearbox Handwheel Shaft & Collar**



Part No. **VR 001**
Description **Main Pressure Gauge**



Part No. **VR 002**
Description **Valve Pressure Gauge**



Part No. **VR 003**
Description **Gas Regulator And Hose**



Part No. **VR 004**
Description **Safety Valve**



Part No. **VR 005**
Description **Safety Valve Actuator**



Part No. **VR 006**
Description **Seat/Charge Valve**



Part No. **VR 007**
Description **Release Valve**



Part No. **VR 008**
Description **Pressure Relief Valve**



Part No. **VR 009**
Description **Unidirectional Check Valve**



Part No. **VR 010**
Description **5/8 Pipe Tee**



Part No. **VR 011**
Description **1/4 Tee**



Part No. **VR 012**
Description **5/8 Elbow**



Part No. **VR 013**
Description **1/4 Elbow**



Part No. **VR 014**
Description **5/8 Coupler**



Part No. **VR 015**
Description **1/4 Coupler**



Part No. **VR 016**
Description **Inlet Snap Coupler**



Part No. **VR 017**
Description **Firing Silencer**



Part No. **VR 018**
Description **Manual Firing Valve**



Part No. **ER 001**
Description **Electric Release Charger**



Part No. **ER 002**
Description **Electric Release Firing Control**



Part No. **ER 003**
Description **Electric Firing Valve**



Part No. **ER 004**
Description **Spare Battery for Firing Control**



Part No. **ER 005**
Description **Firing Snap Coupler**



Part No. **AC 01**
Description **Elevation Meter**



Part No. **AC 03**
Description **High Pressure Gas Regulator and Hose for shots over 450 PSI**



Part No. **AC 02**
Description **Cover**

PNEUMATIC CONTROL DIAGRAM APPENDIX G

